



BLACKBELL150 INDUSTRIAL SERIES

KAP-HBBL-150



Electrical / Electrique

Power / Puissance	150 W
Input voltage / Tension d'entrée	100 - 277 V
Input current / Courant d'entrée	0.65 A @ 230 v
Frequency / Fréquences	50 - 60 Hz
Power factor / Facteur de puissance	> 0.95
Dimmable type / Type de dimmage	0-10 V

Lighting / Eclairage

Beam angle / Angle de faisceau	120°
Efficiency / Efficacité	110 Lumens/w
Lumen output / Sortie lumens	16500Lumens
CRI / IRC	> 80
Color temperature / Température de couleur	4000 - 4500 K 4800 - 5100 K 5200 - 5700 K

Components & fixture / Composants et structure

Body material / Matériau du corps du projecteur	Aluminum / Aluminium
Product painting color / Couleur de la peinture	Black / Noir
Screws material / Matériau des visseries	SS316 / Inox 316
Cover material / Matériau du couvercle	PC cover / Couvercle en PC
Cable specifications / Spécifications du cable	H05RNF (3G1.0mm ²)
LED Chipset / Puces LED	Lumileds Luxeon 3030
Cable length / Longueur du cable	2.0m

Temperatures / Températures

Storage temperature / <i>Température de stockage</i>	-40°C ~ +80°C
Operating temperature / <i>Température d'utilisation</i>	-20°C ~ +40°C
Storage Humidity / <i>Humidité de stockage</i>	10% - 90%

Additional product data / Informations supplémentaires

Lifetime / <i>Durée de vie</i>	> 50.000 Hours
Warranty / <i>Garantie</i>	5 years / 5 ans
International Standards / <i>Normes internationales</i>	Eco-Design(ERP)



Model number / Numéro de référence

Example for BLACKBELL150 with balck painting / color temperature 4000K / 2.0m cable
Exemple pour BLACKBELL150 avec peinture noir / couleur de temperature 4000k / cable 2.0m

KAP -HBBL -150 -B 4 -C20

BLACKBELL series with Lumileds LED chipsets
Gamme BLACKBELL avec puces LED Lumileds

Power / *Puissance* : **150w**

Product painting color / *Couleur de la peinture*
Black(*Noir*)

Cable length / *Longueur du cable* :
2.0m

Color temperature / *Température de couleur*
4(4000-4500K)
5(4800-5100K)
6(5200-5700K)

Product Dimensions

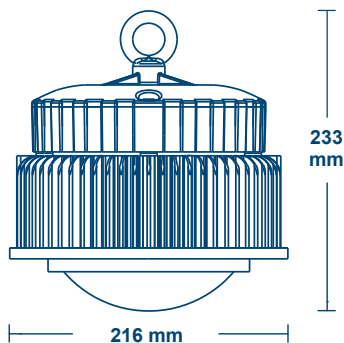

Photometry / Photométrie

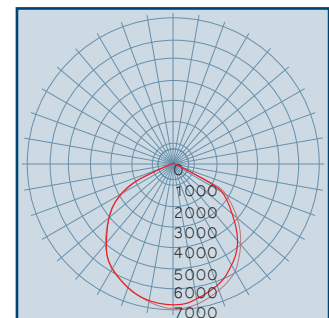

Packing Information / Information Colisage

Packing details	Size (mm)	Qty / ctn(pcs)	Net Weight (kg)	Gross Weight (kg)
Product	216*216*233	/	4	/
Inner box	230*230*220	1	/	4.25
Master Carton	480*480*240	4	16	17